

Note 1: For MS-II daughtercard implementation, the following signals apply to DIP-40 socket:

- 6 - CANHout
- 11 - CANLout
- 16 - V12 for IAC stepper
- 17 - IGN
- 18 - Knk Window
- 35 - IAC2B
- 36 - IAC2A
- 37 - IAC1B
- 38 - IAC1A

Note 2: Jumper location JS9 (pin 16) tied to +12V for MS-II CPU board implementation for enabling IAC stepper driver.

Title		
Megasquirt - CPU - B. A. Bowling		
Size	Document Number	Rev
A	Rev 3.57M - SMD	3.57
Date:	Monday, February 19, 2007	Sheet 1 of 8

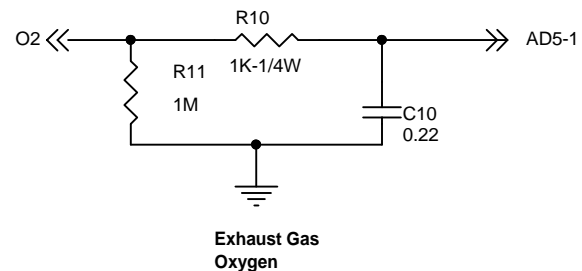
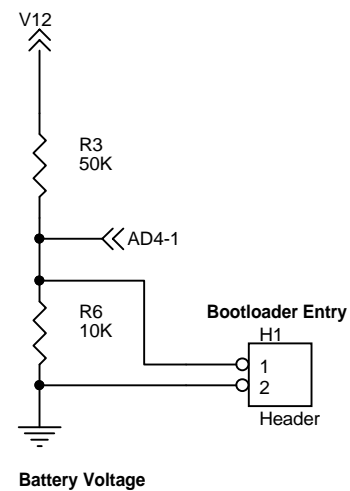
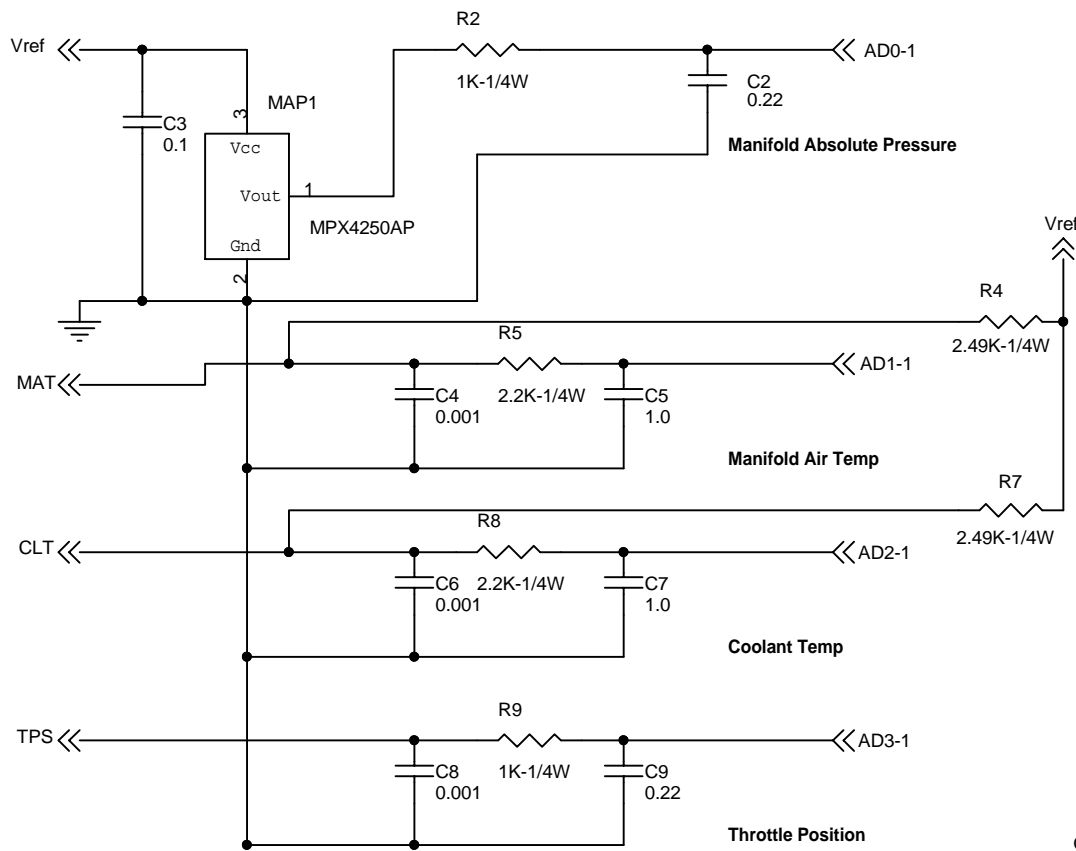

Title		
Megasquirt - Input		
Size	Document Number	Rev
A	Rev 3.57M - SMD	3.57
Date:	Monday, February 19, 2007	Sheet 2 of 8

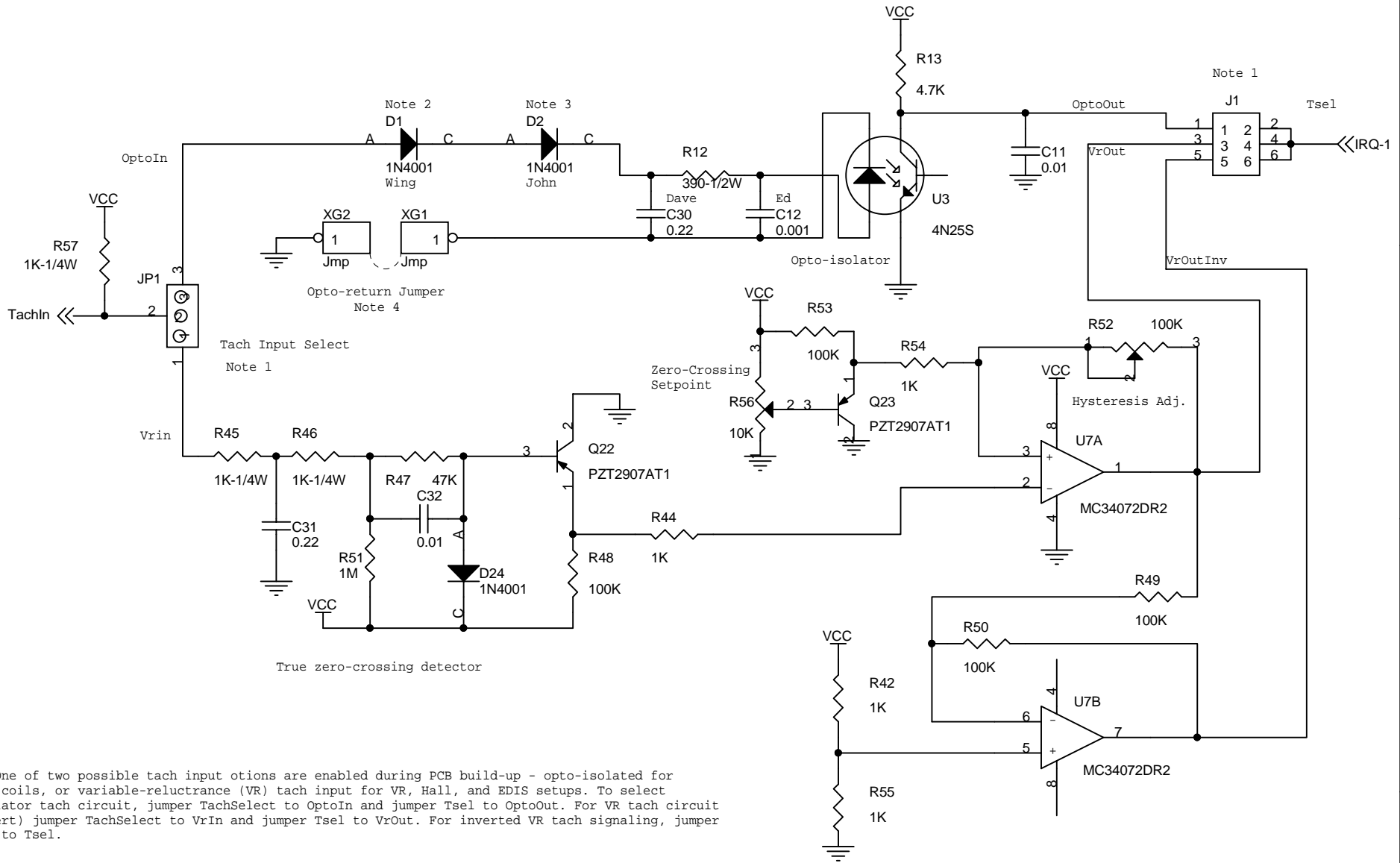

Note 1: One of two possible tach input options are enabled during PCB build-up - opto-isolated for ignition coils, or variable-reluctance (VR) tach input for VR, Hall, and EDIS setups. To select opto-isolator tach circuit, jumper TachSelect to OptoIn and jumper Tsel to OptoOut. For VR tach circuit (non-invert) jumper TachSelect to VrIn and jumper Tsel to VrOut. For inverted VR tach signaling, jumper VrOutInv to Tsel.

Note 2: Diode D1 may not be needed with hall sensor (operating at 5 volts) - install jumper in its place.

Note 3: Diode D2 is normally a 1N4001 installed to add an additional 0.7V forward series voltage drop (i.e. $D1 + D2 + V_{f_opto_diode} = 0.7 + 0.7 + 1.2 = 2.6V$). For hall sensor use, install jumper in place of diode. To use in ignition coil primary flyback pulse detection trigger, replace with 24V zener (connected in reverse, operate in avalanche mode), eliminate C30, and lower C12 value to 470pF.

Note 4: Jumper locations XG1 and XG2 normally jumpered. For extreme ignition coil noise, XG1 can be grounded directly to engine via external connection. XG1 can also be used for Hall sensor open-collector operation.

Title		
Megasquirt - Tach Input		
Size	Document Number	Rev
A	Rev 3.57M - SMD	3.57
Date:	Monday, February 19, 2007	Sheet 3 of 8

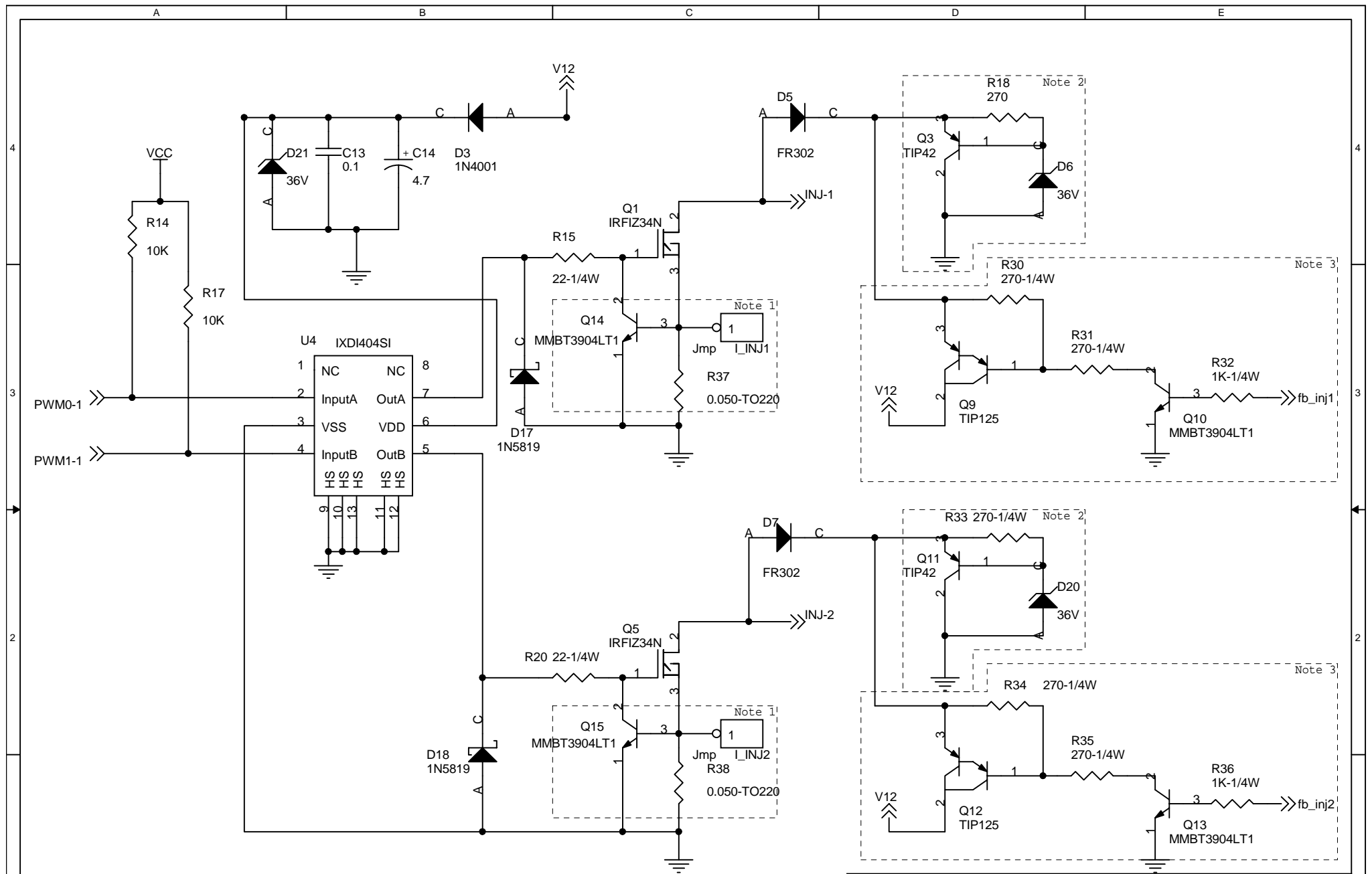

Note 1: Current limit circuit for driver FET protection. Clamp current set to ~14 amps. Circuit can be omitted if protection is not required or desired - in this case install jumper in place of R37 and R38

Note 2: Active flyback clamp circuit. If using avalanche-rated FETs for Q1/Q5 then circuit can be omitted. Clamp voltage equals zener avalanche voltage.

Note 3: Flyback PWM damping circuit. Circuit can be omitted if PWM current limiting not used.

Title		
Megasquirt - Output Injector		
Size	Document Number	Rev
A	Rev 3.57M - SMD	3.57
Date:	Monday, February 19, 2007	Sheet 4 of 8

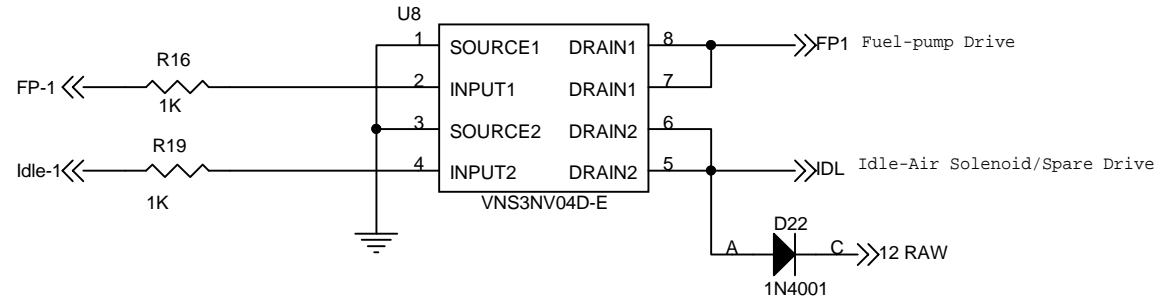
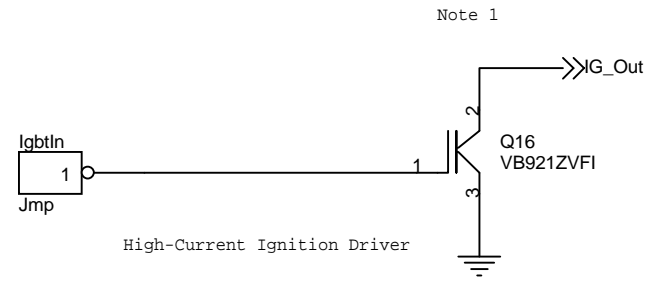

Note 1: High-power ignition drive, optional circuit - populate only if implementing drive.

Title		
Megasquirt - Output Other		
Size	Document Number	Rev
A	Rev 3.57M - SMD	3.57
Date:	Friday, February 09, 2007	Sheet 5 of 8

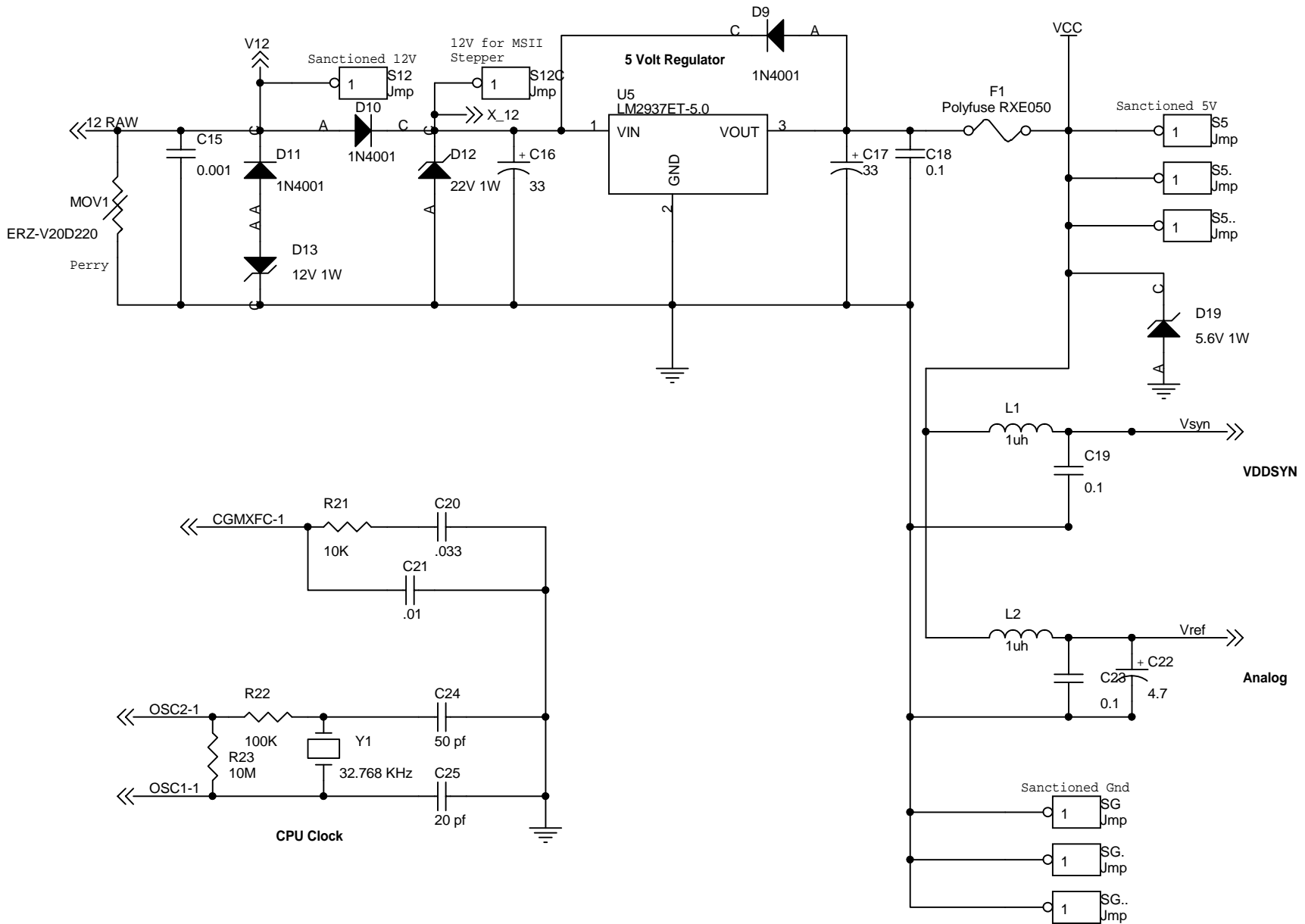

Title		
Megasquirt - Power		
Size	Document Number	Rev
A	Rev 3.57M - SMD	3.57
Date:	Monday, February 19, 2007	Sheet 6 of 8

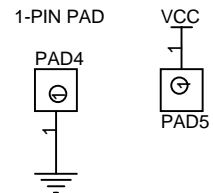
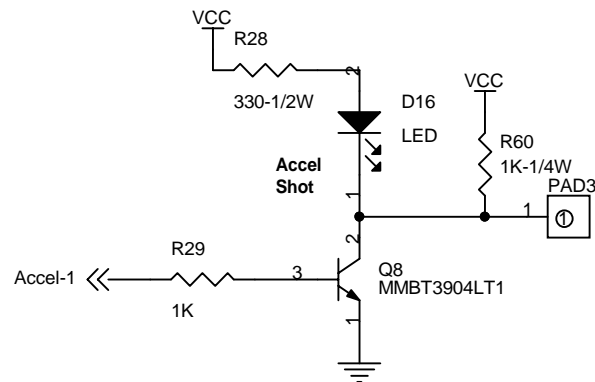
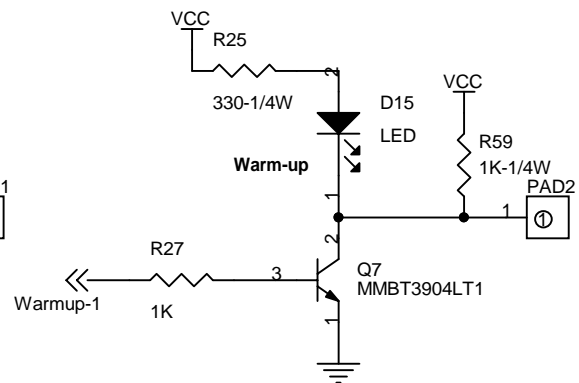
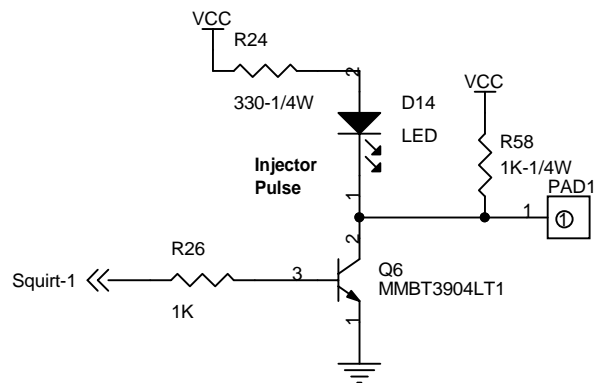

Title		
MegaSquirt - LED Indicators		
Size	Document Number	Rev
A	Rev 3.57M - SMD	3.57
Date:	Monday, February 19, 2007	Sheet 7 of 8

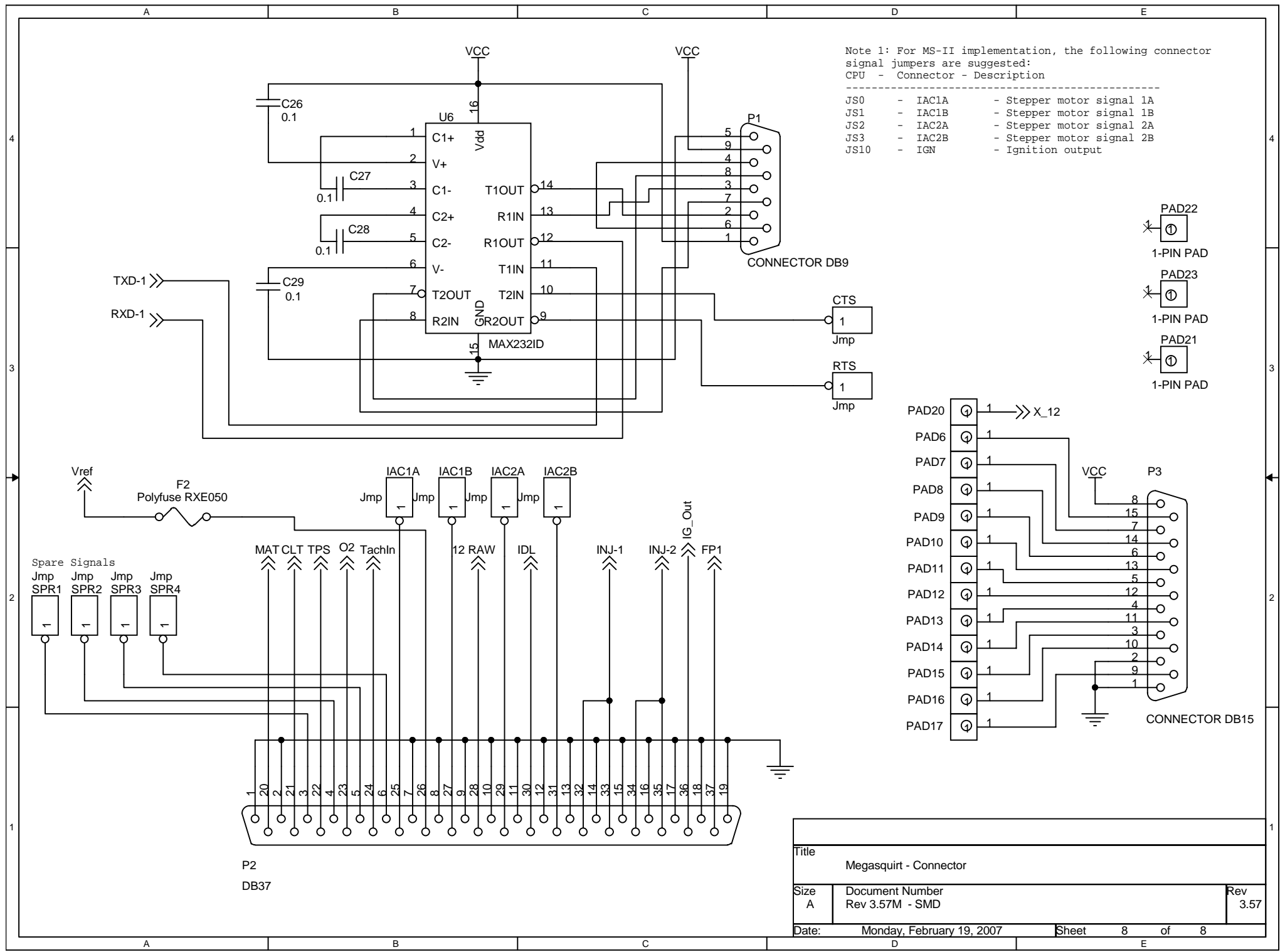

Note 1: For MS-II implementation, the following connector signal jumpers are suggested:

Connector	Description
JS0	IAC1A - Stepper motor signal 1A
JS1	IAC1B - Stepper motor signal 1B
JS2	IAC2A - Stepper motor signal 2A
JS3	IAC2B - Stepper motor signal 2B
JS10	IGN - Ignition output

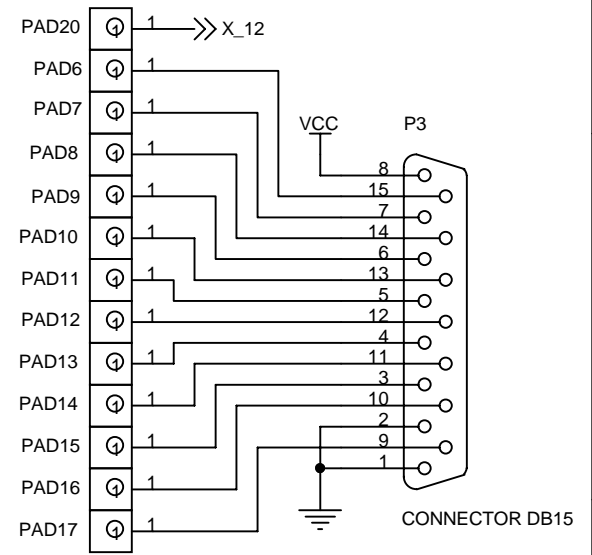
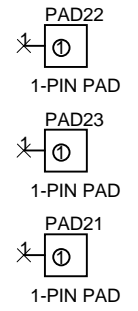

P2
DB37

Title		
Megasquirt - Connector		
Size	Document Number	Rev
A	Rev 3.57M - SMD	3.57
Date:	Monday, February 19, 2007	Sheet 8 of 8